

INSTRUCTION BULLETIN

IRIG-B Distribution Module (IDM) STR-IDM



The Cyber Sciences' Satellite Time Reference IRIG-B Distribution Module (STR-IDM) enables the distribution of an unmodulated IRIG-B signal over long distances and to multiple devices. The STR-IDM gets its 24V IRIG-B signal and power from a PLX-24V (attached to a CyTime™ Sequence of Event Recorder) or STR-100/IRIG-B Satellite Time Reference.

Each STR-IDM provides eight (8) IRIG-B outputs. These outputs are electrically isolated from the source device (e.g., PLX-24) to eliminate concerns about multiple ground references. The STR-IDM requires no separate power supply; it derives its own power by DC-DC conversion of a voltage carried on the daisy chain link from the master PLX-24V or STR-100/IRIG-B.

Depending on distance, up to 4 STR-IDM modules can be connected to each 24V IRIG-B output in a multi-point system. This allows the user maximum flexibility in system layout and design. Thus, a total of 64 IRIG-B devices may be synchronized from a single STR-100/IRIG-B or 32 devices from a PLX-24V time reference.

SAFETY PRECAUTIONS

DANGER

HAZARD OF ELECTRIC SHOCK, EXPLOSION, OR ARC FLASH

- Only qualified workers should install this equipment. Such work should be performed only after reading this entire set of instructions.
- NEVER work alone.
- Before performing visual inspections, tests, or maintenance on this equipment, disconnect all sources of electric power. Assume that all circuits are live until they have been completely de-energized, tested, and tagged. Pay particular attention to the design of the power system. Consider all sources of power, including the possibility of backfeeding.
- Apply appropriate personal protective equipment (PPE) and follow safe electrical practices. For example, in the USA, see NFPA 70E.
- Turn off all power supplying the equipment before installing and wiring this device.
- Always use a properly rated voltage sensing device to confirm that power is off.
- Beware of potential hazards, wear personal protective equipment, and carefully inspect the work area for tools and objects that may have been left inside the equipment.
- The successful operation of this equipment depends upon proper handling, installation, and operation. Neglecting fundamental installation requirements may lead to personal injury as well as damage to electrical equipment or other property.

Failure to follow these instructions will result in death or serious injury.

INSTALLATION

DIN-Rail Mounting

The STR-IDM is designed for mounting on a standard DIN rail, as shown.

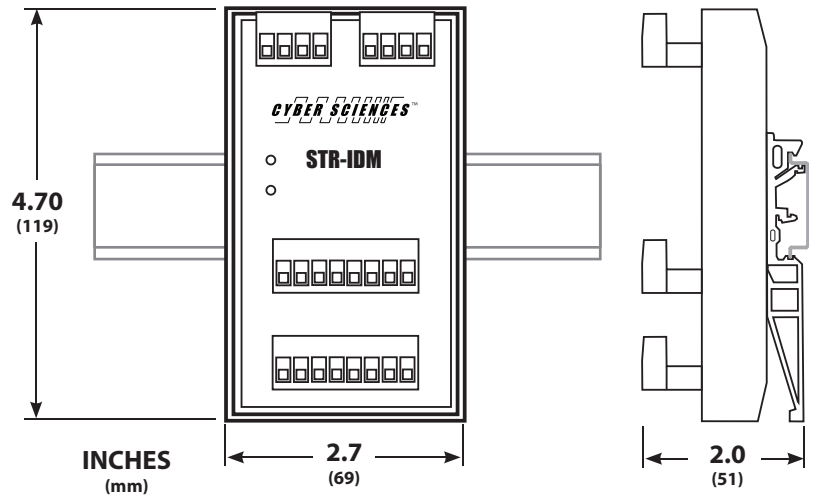

STR-IDM DIN-rail mounting — Front and side views, with dimensions

WIRING

Typically, IRIG-B signals are wired point-to-point. The IDM greatly simplifies wiring of IRIG-B devices by allowing distribution of the IRIG-B time signal over multi-point communications over longer distances and to a greater number of devices.

The first STR-IDM in the sequence gets its 24 Vdc IRIG-B signal and control power from the 24V IRIG-B master: a PLX-24V (PTP Legacy Interface for CyTime SER) or STR-100/IRIG-B.

Physical Wiring Connections

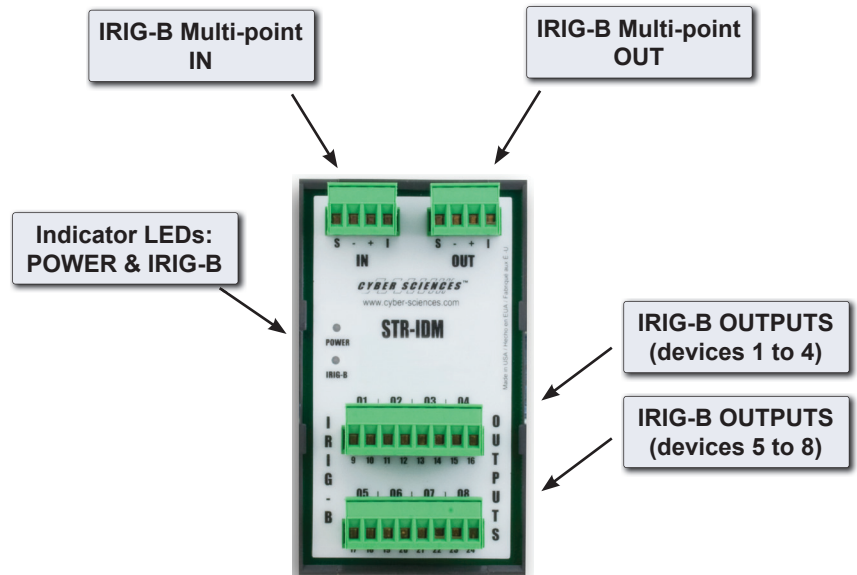

STR-IDM physical wiring connections (and indicators)

WIRING (continued)

**24V IRIG-B Master Connections
(PLX-24V or STR-100/IRIG-B)**

The wiring of the 24V IRIG-B signal and 24Vdc control power at the 24V IRIG-B master (PLX-24V or STR-100/IRIG-B) is shown below. Please refer to the instruction bulletins of these devices for more details.

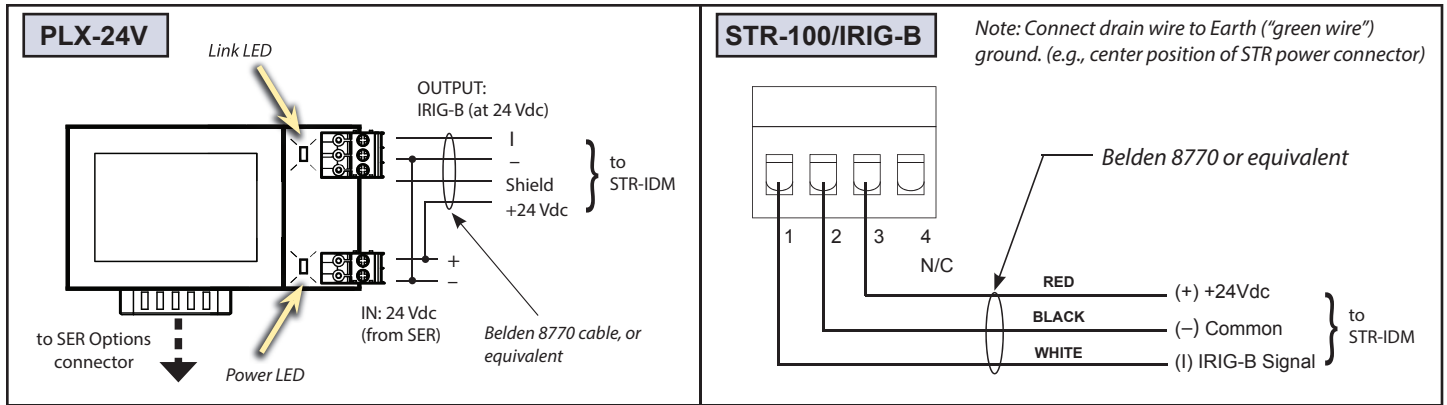

**IRIG-B Multi-point Input Connections
(from 24V IRIG-B Master or previous IDM)**

Wiring of the IRIG-B multi-point input and output connectors of the STR-IDM (top) are shown in the next two drawings. The colors shown are for Belden 8770 cable.

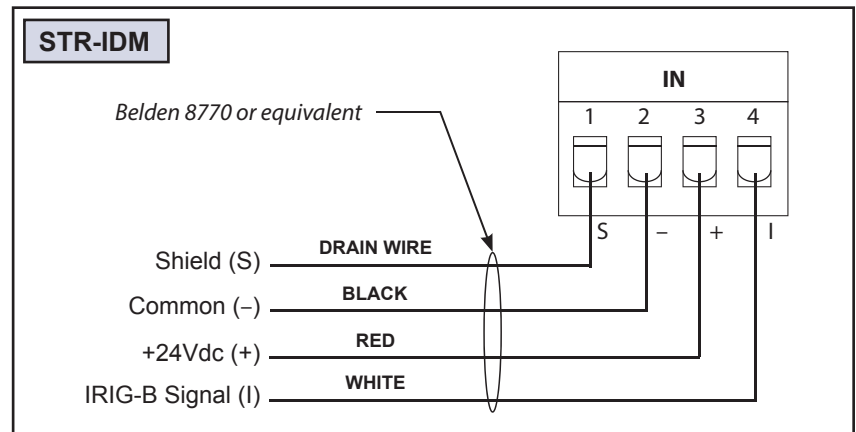
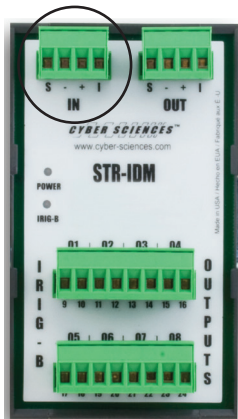

STR-IDM multi-point IRIG-B input connections (from PLX-24V or STR-100/IRIG-B)

**IRIG-B Multi-point Output Connections
(to another IDM)**

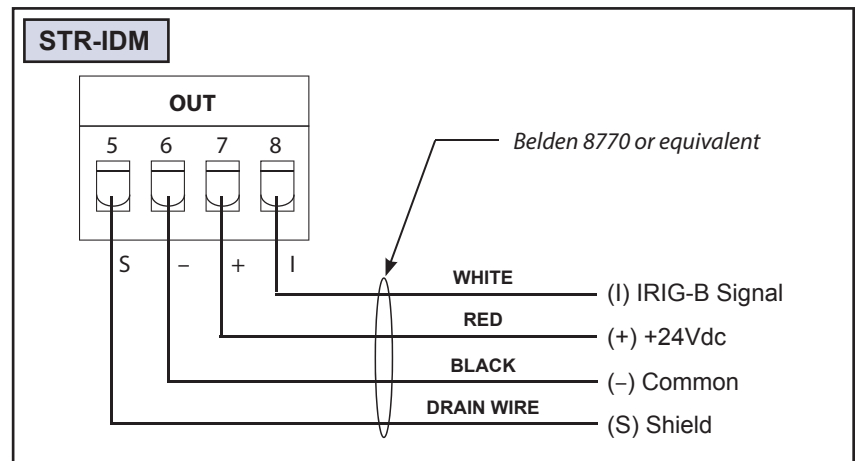
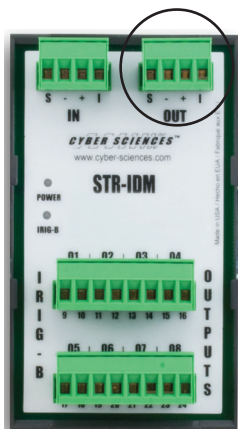

STR-IDM multi-point IRIG-B output connections (to another IDM)

WIRING (continued)

**IRIG-B Output Connections
(to IRIG-B devices)**

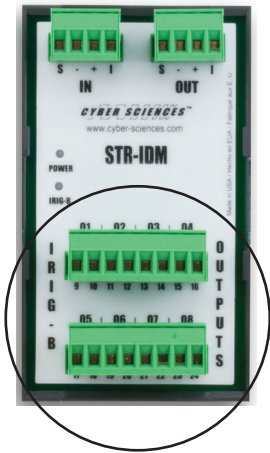

This drawing shows the wiring of IRIG-B outputs to devices to be synchronized via unmodulated IRIG-B (5V DCLS).

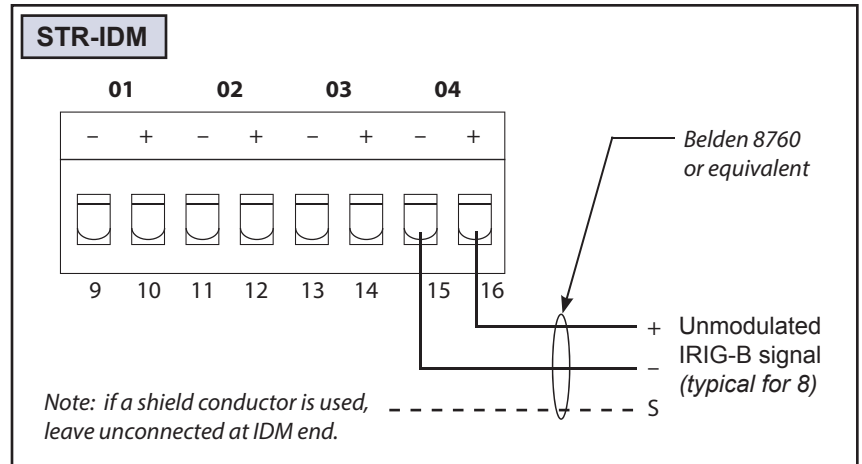

STR-IDM IRIG-B output connections (to devices requiring IRIG-B)

TECHNICAL SPECIFICATIONS

SPECIFICATIONS

Indicator LEDs	Power—Indicates control power input IRIG-B—Flashing when IRIG-B signal is active
Standard IRIG-B Outputs	Eight (8) 5V DCLS IRIG-B outputs (5Vdc nominal): Vlow (max. voltage for logical "0") = 0.4 volts @ 24 mA Vhigh (min. voltage for logical "1") = 3.2 volts @ -15 mA
Power Requirements	24Vdc +/- 10% (from PLX-24V or STR-100/IRIG-B). No separate power supply required.
Isolation	> 1000 Vac rms between power and signal inputs and outputs. All inputs / outputs include transient protection.
Environmental	-30°C to +80°C ambient operating temperature. -40°C to +85°C storage temperature. Humidity 5-95% (non-condensing) at 40°C.
Mounting	DIN-rail mount. All connectors and indicators on front.
Dimensions	2.7 in. wide x 4.7 in. high x 2.0 in. deep (69 x 119 x 51 mm)
Weight	Approximately 5 oz. (143g)



Doc. no: IB-IDM-01 January-2022
(Supersedes doc. dated April-2016)

Cyber Sciences, Inc. USA

© CyTime and the Cyber Sciences stylized logo are trademarks of Cyber Sciences. All other trademarks are the property of their respective owners.